

N112W14600 Mequon Road
 Germantown, WI 53022
 www.electriceheat.com

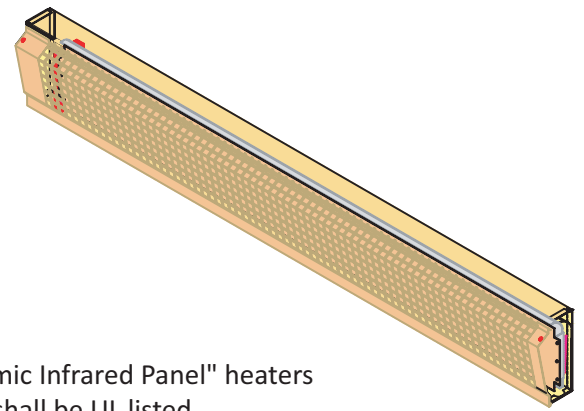

ARCHITECT'S AND ENGINEER'S SPECIFICATIONS

Furnish and install where indicated on the Drawings, "High Efficiency Ceramic Infrared Panel" heaters manufactured by Radiant Electric Heat. Germantown, Wisconsin. Heaters shall be UL listed.

CONSTRUCTION

Heating Elements: Porcelain enamel coated 18 gauge steel plate, with energizing ceramic circuit on internal face of heating element; minimum 2.8 Watts per square inch of emissive surface area.

Heater Body: 20 gauge steel, high-temperature resistant powder coating. Provided with manufacturer's standard 7/8 inch knockouts for power feed.

Accessories: Provide as indicated, thermostat, NEMA 1 Enclosure control panel, and protective grill for models specified.

Installation: Install heating units where indicated, in accordance with manufacturer's written instructions, applicable requirements of IEC, in compliance with recognized industry practices to ensure products fulfill requirements. Top of heater unit and trim shall be level. Where heating units are mounted adjacent to each other, the top edges shall be at the same height.

SPECIFICATIONS

MODEL	INSTALLATION	WATTS	VOLTAGE/AMPS		SHIPPING WEIGHT
527B	BASEBOARD	400	120 VAC/3.33 A 240 VAC/1.67 A	208 VAC/1.92 A 277 VAC/1.44 A	14 lbs
545B	BASEBOARD	650	120 VAC/5.42 A 240 VAC/2.71 A	208 VAC/3.22 A 277 VAC/2.35 A	20 lbs

*RADIANT ELECTRIC HEAT RESERVES THE RIGHT TO CHANGE SPECIFICATIONS WITHOUT PRIOR NOTICE.

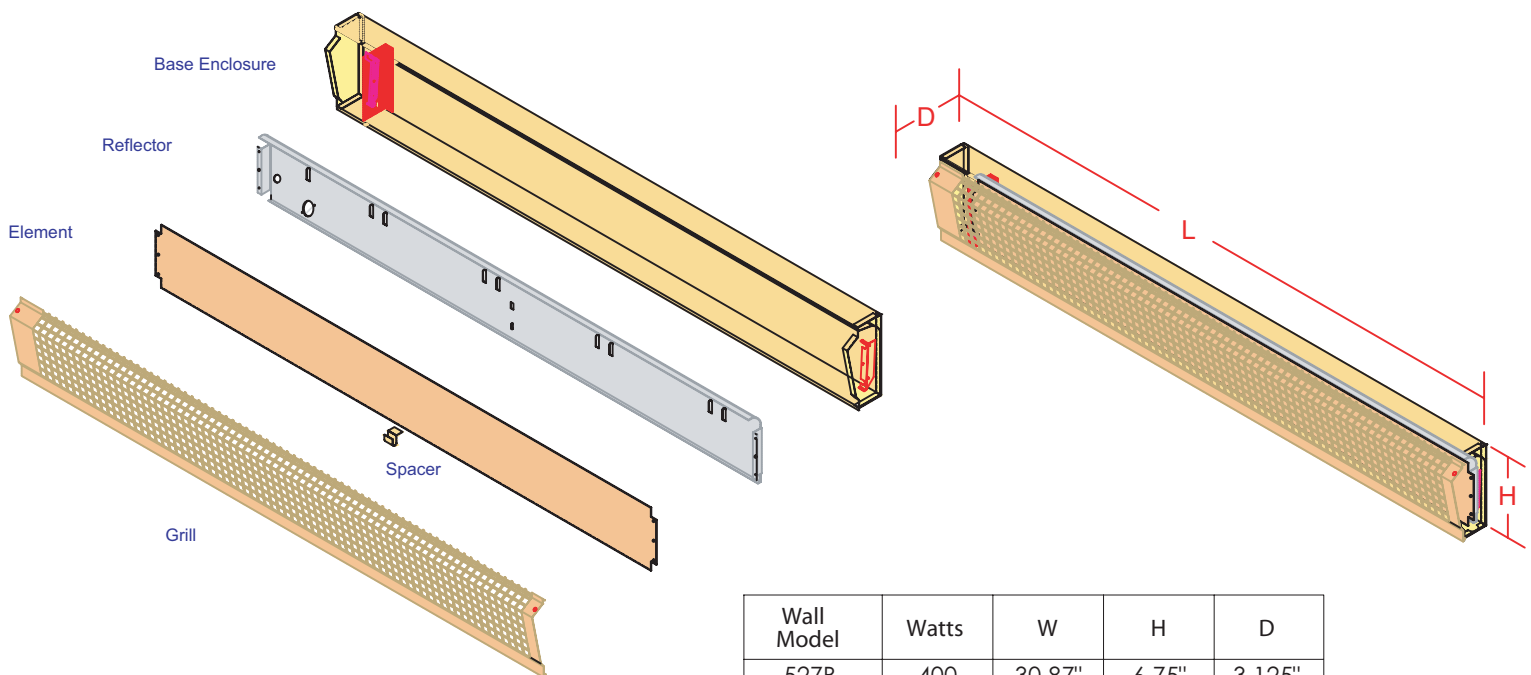

Wall Model	Watts	W	H	D
527B	400	30.87"	6.75"	3.125"
545B	650	48"	6.75"	3.125"